



DEPARTMENT OF REGULATORY AND ECONOMIC RESOURCES (RER)  
BOARD AND CODE ADMINISTRATION DIVISION

MIAMI-DADE COUNTY  
PRODUCT CONTROL SECTION

11805 SW 26 Street, Room 208  
T (786) 315-2590 F (786) 315-2599

**NOTICE OF ACCEPTANCE (NOA)**

[www.miamidade.gov/economy](http://www.miamidade.gov/economy)

**Lawson Industries, Inc.**  
8501 NW 90 Street  
Medley, FL 33166

**SCOPE:**

This NOA is being issued under the applicable rules and regulations governing the use of construction materials. The documentation submitted has been reviewed and accepted by Miami-Dade County RER - Product Control Section to be used in Miami Dade County and other areas where allowed by the Authority Having Jurisdiction (AHJ).

This NOA shall not be valid after the expiration date stated below. The Miami-Dade County Product Control Section (In Miami Dade County) and/or the AHJ (in areas other than Miami Dade County) reserve the right to have this product or material tested for quality assurance purposes. If this product or material fails to perform in the accepted manner, the manufacturer will incur the expense of such testing and the AHJ may immediately revoke, modify, or suspend the use of such product or material within their jurisdiction. RER reserves the right to revoke this acceptance, if it is determined by Miami-Dade County Product Control Section that this product or material fails to meet the requirements of the applicable building code.

This product is approved as described herein, and has been designed to comply with the Florida Building Code, including the High Velocity Hurricane Zone.

**DESCRIPTION: Series "SH-7600 (Fin Frame)" Aluminum Single Hung Window - N.I.**

**APPROVAL DOCUMENT:** Drawing No. L7600-0402, titled "SH-7600 Single Hung Fin Window", sheets 1 through 5 of 5, dated 09/20/04, with revision F dated 11/01/17, prepared by the manufacturer, signed and sealed by Thomas J. Sotos, P.E., bearing the Miami-Dade County Product Control Section Renewal stamp with the Notice of Acceptance number and expiration date by the Miami-Dade County Product Control Section.

**MISSILE IMPACT RATING: None**

**LABELING:** Each unit shall bear a permanent label with the manufacturer's name or logo, city, state, model/series, and following statement: "Miami-Dade County Product Control Approved", unless otherwise noted herein.

**RENEWAL** of this NOA shall be considered after a renewal application has been filed and there has been no change in the applicable building code negatively affecting the performance of this product.

**TERMINATION** of this NOA will occur after the expiration date or if there has been a revision or change in the materials, use, and/or manufacture of the product or process. Misuse of this NOA as an endorsement of any product, for sales, advertising or any other purposes shall automatically terminate this NOA. Failure to comply with any section of this NOA shall be cause for termination and removal of NOA.

**ADVERTISEMENT:** The NOA number preceded by the words Miami-Dade County, Florida, and followed by the expiration date may be displayed in advertising literature. If any portion of the NOA is displayed, then it shall be done in its entirety.

**INSPECTION:** A copy of this entire NOA shall be provided to the user by the manufacturer or its distributors and shall be available for inspection at the job site at the request of the Building Official.

This NOA revises NOA# 15-0511.04 and consists of this page 1 and evidence pages E-1 and E-2, as well as approval document mentioned above.

The submitted documentation was reviewed by **Sifang Zhao, P.E.**



S.Z.  
01/26/2018

NOA No. 17-1212.19  
Expiration Date: July 07, 2020  
Approval Date: February 01, 2018  
Page 1

**NOTICE OF ACCEPTANCE: EVIDENCE SUBMITTED**

**A. DRAWINGS**

1. Manufacturer's die drawings and sections.  
*(Submitted under NOA No.05-0324.06)*
2. Drawing No. **L7600-0402**, titled "SH-7600 Single Hung Fin Window", sheets 1 through 5 of 5, dated 09/20/04, with revision **F** dated 11/01/17, prepared by manufacturer, signed and sealed by Thomas J. Sotos, P.E.

**B. TESTS**

1. Test reports on: 1) Air Infiltration Test, per FBC, TAS 202-94  
2) Uniform Static Air Pressure Test, Loading per FBC TAS 202-94  
3) Water Resistance Test, per FBC, TAS 202-94  
4) Forced Entry Test, per FBC 2411.3.2.1, and TAS 202-94  
along with marked-up drawings and installation diagram of an aluminum single hung window-fin mounted, prepared by Fenestration Testing Laboratories, Inc., Test Report No. **FTL-5284**, dated on 09/14/07, and addendum letter dated 07/21/08, all signed and sealed by Michael R. Wenzel, P.E. *(Submitted under NOA No.07-1029.05)*
2. Test reports on: 1) Air Infiltration Test, per FBC, TAS 202-94  
2) Uniform Static Air Pressure Test, Loading per FBC TAS 202-94  
3) Water Resistance Test, per FBC, TAS 202-94  
4) Forced Entry Test, per FBC 2411.3.2.1, and TAS 202-94  
along with marked-up drawings and installation diagram of aluminum single hung windows - (fin/flange mounted), prepared by Fenestration Testing Laboratory, Inc., Test Reports No. **FTL-4324, FTL-4350, FTL-4351, FTL-4346, FTL-4363, FTL-4323, FTL-4406** and **FTL-4405**, all dated 11/08/04 and 11/12/04, signed and sealed by Edmundo J. Largaespada, P.E. *(Submitted under NOA No.05-0324.06)*

**C. CALCULATIONS**

1. Anchor verification calculations and structural analysis, complying with FBC, dated 08/04/09, prepared by manufacturer, signed and sealed by Thomas J. Sotos, P.E.  
*(Submitted under NOA No. 09-0720.06)*
2. Glazing complies with **ASTM E1300-04/09**

**D. QUALITY ASSURANCE**

1. Miami-Dade Department of Regulatory and Economic Resources (RER).

**E. MATERIAL CERTIFICATIONS**

1. None.



---

Sifang Zhao, P.E.  
Product Control Examiner  
NOA No. 17-1212.19  
Expiration Date: July 07, 2020  
Approval Date: February 01, 2018

NOTICE OF ACCEPTANCE: EVIDENCE SUBMITTED

**F. STATEMENTS**

1. Statement letter of conformance, complying with **FBC 6<sup>th</sup> Edition (2017)**, dated 11/17/17, issued by manufacturer, signed and sealed by Thomas J. Sotos, P.E.
2. Statement letter of no financial interest, dated 07/07/09, signed and sealed by Thomas J. Sotos, P.E.  
*(Submitted under previous NOA No. 09-0720.06)*
3. Laboratory compliance letter for Test Report No. **FTL-5284**, issued by Fenestration Testing Laboratory, Inc., dated 09/14/07, signed and sealed by Michael R. Wenzel, P.E.  
*(Submitted under previous NOA No. 07-1029.05)*
4. Laboratory compliance letter for Test Reports No. **FTL-4324, FTL-4350, FTL-4346, FTL-4363, FTL-4323, FTL-4406 and FTL-4405**, issued by Fenestration Testing Laboratory, Inc., all dated 11/08/04 and 11/12/04, all signed and sealed by Edmundo J. Largaespada, P.E.  
*(Submitted under NOA No.05-0928.02)*

**G. OTHERS**

1. Notice of Acceptance No. **15-0511.04**, issued to Lawson Industries, Inc. for their Series "7600 (Fin Frame)" Aluminum Single Hung Window – N.I., approved on 06/25/15 and expiring on 07/07/20.



---

Sifang Zhao, P.E.  
Product Control Examiner  
NOA No. 17-1212.19

Expiration Date: July 07, 2020  
Approval Date: February 01, 2018

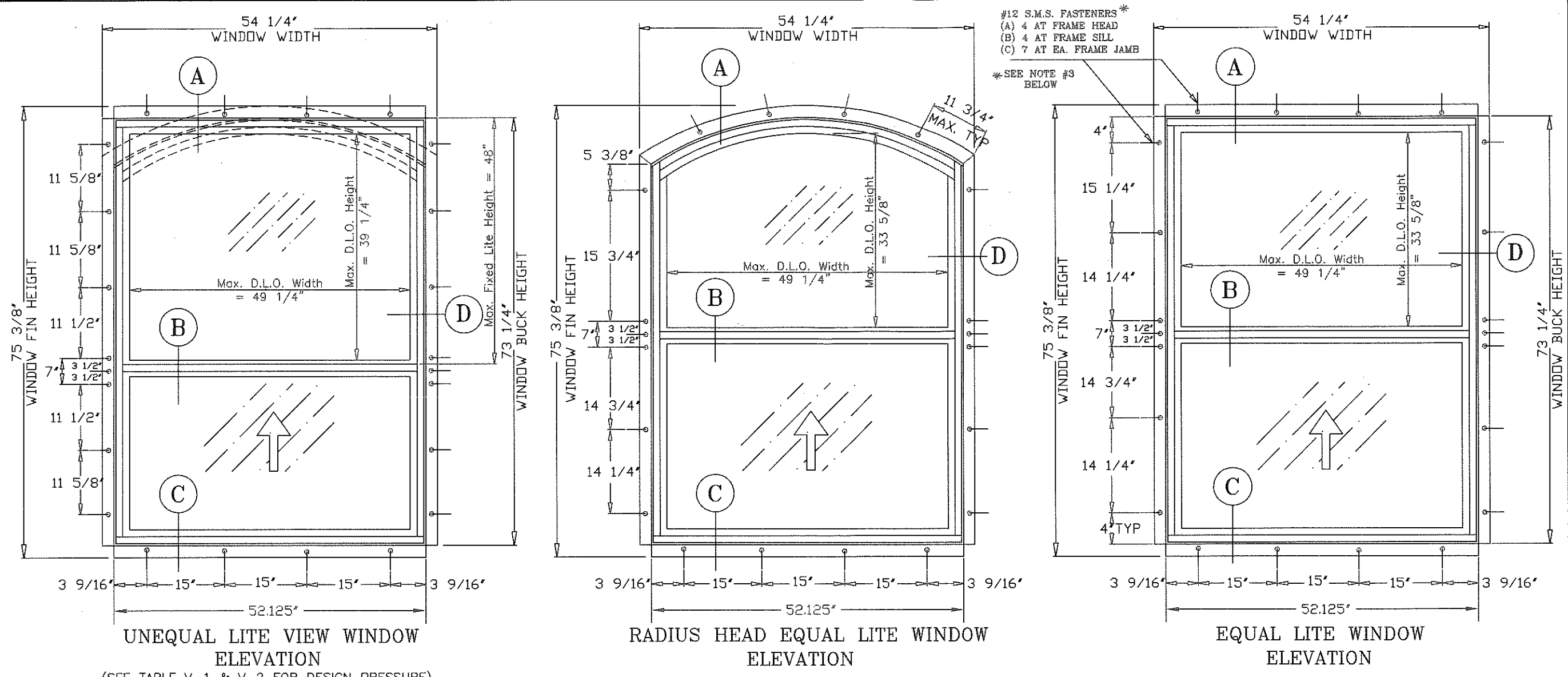

(SEE TABLE V-1 & V-2 FOR DESIGN PRESSURE)

**SERIES-7600 SINGLE HUNG WINDOW - FIN FRAME - NON-IMPACT**

**NOTES:**

- 1.) THIS WINDOW SYSTEM IS DESIGNED AND TESTED TO COMPLY WITH THE REQUIREMENTS OF THE FLORIDA BUILDING CODE (2014-5th Edition & 2017-6th Edition) AND ASTM 1300-09. THIS PRODUCT IS NOT IMPACT RESISTANT. WINDOWS ARE TO BE PROTECTED WITH A MIAMI-DADE COUNTY APPROVED IMPACT RESISTANT SHUTTER.
- 2.) 1 X OR 2 X WOOD BUCKS SHALL BE INSTALLED AND ANCHORED SO THAT THE BUILDING RESISTS THE SUPERIMPOSED LOADS IN ACCORDANCE WITH REQUIREMENTS OF 2017 F.B.C. & TO BE REVIEWED BY BUILDING OFFICIAL.
- 3.) ANCHORS SHOWN ABOVE ARE AS PER TEST UNITS. EXTERIOR ANCHOR SPACINGS WILL VARY WITH UNIT DIMENSIONS, AND THE NUMBER OF ANCHORS REQUIRED, AS SPECIFIED ON THE LOAD TABLES AT SHEET 3 & 4.
- 4.) ANCHOR CONDITIONS NOT DESCRIBED IN THESE DRAWING'S ARE TO BE ENGINEERED ON A SITE SPECIFIC BASIS, UNDER SEPARATE APPROVAL AND TO BE REVIEWED BY BUILDING OFFICIAL.
- 5.) RADIUS HEAD WINDOWS ARE QUALIFIED FOR USE WITH ALL GLASS TYPES TABULATED HEREIN. HEREIN.
- 6.) VIEW WINDOWS ARE QUALIFIED FOR USE WITH 3/16" ANNEALED & 3/16" TEMPERED GLASS USING THE HEAVY DUTY MEETING RAIL ONLY.
- 7.) SEE SHEET #5 FOR SASH LOCK OPTIONS & NOTES.
- 8.) SEE SHEET #4 FOR GLAZING DETAILS & OPTIONS. (REFER TO SHEETS 3, & 4 FOR DESIGN PRESSURES.
- 9.) WOOD OPENING SHALL BE PROTECTED WITH AN APPROVED MOISTURE RESISTANT BARRIER (BY OTHERS), PRIOR TO WINDOW INSTALLATION. (SEE SHEET #2 FOR DETAIL & NOTES.
- 10.) APPROVAL APPLIES TO SINGLE UNITS, OR MULTIPLE UNITS AND MAY BE MULLED VERTICALLY OR HORIZONTALLY.
- 11.) MULLING SINGLE HUNG WINDOWS WITH OTHER TYPES OF MIAMI-DADE COUNTY APPROVED WINDOWS USING A MIAMI-DADE COUNTY APPROVED MULLION IN BETWEEN ARE ACCEPTABLE BUT THE LOWER PRESSURE FROM THE WINDOWS OR MULLION APPROVAL WILL APPLY TO THE ENTIRE MULLED SYSTEM.
- 12.) SEE SHEET # 5 FOR MULLION/METAL ATTACHMENT DETAILS & NOTES.

WINDOWS ARE TO BE PROTECTED WITH MIAMI DADE COUNTY APPROVED IMPACT RESISTANT SHUTTERS

PRODUCT REVISED  
as complying with the Florida  
Building Code  
Acceptance No 17-12/2-19  
Expiration Date 07/01/2020  
By *[Signature]*  
Miami Dade Product Control

Revision Notes: B. Qualified Cam Locks on all annealed windows and 1/8" temp. Changed tables to buck dims. C. General notes revised to comply with the 2007 Florida Building Code. D. Revised to Comply w/ 2010 FBC E. Revised to Comply w/ 2014 FBC F. Revised to Comply w/ 2017 FBC		Date Drawn: 09/20/04
Drawn By: N. Erazo	Date Revised: 11/01/17	Scale: F

**LAWSON INDUSTRIES, INC.**

MANUFACTURER OF QUALITY ALUMINUM WINDOWS AND GLASS DOORS

8501 N.W. 90 ST.  
MEDLEY, FLORIDA 33166  
PH No. (305) 696-8660

SH-7600 SINGLE HUNG FIN WINDOW

APPROVED ELEVATIONS, CONFIGURATIONS AND NOTES

Drawing Number: L7600-0402      Sheet: 1 OF 6      Revision #:

THOMAS J. SOTOS  
PROFESSIONAL ENGINEER  
FL. P.C. # 55225

DATE

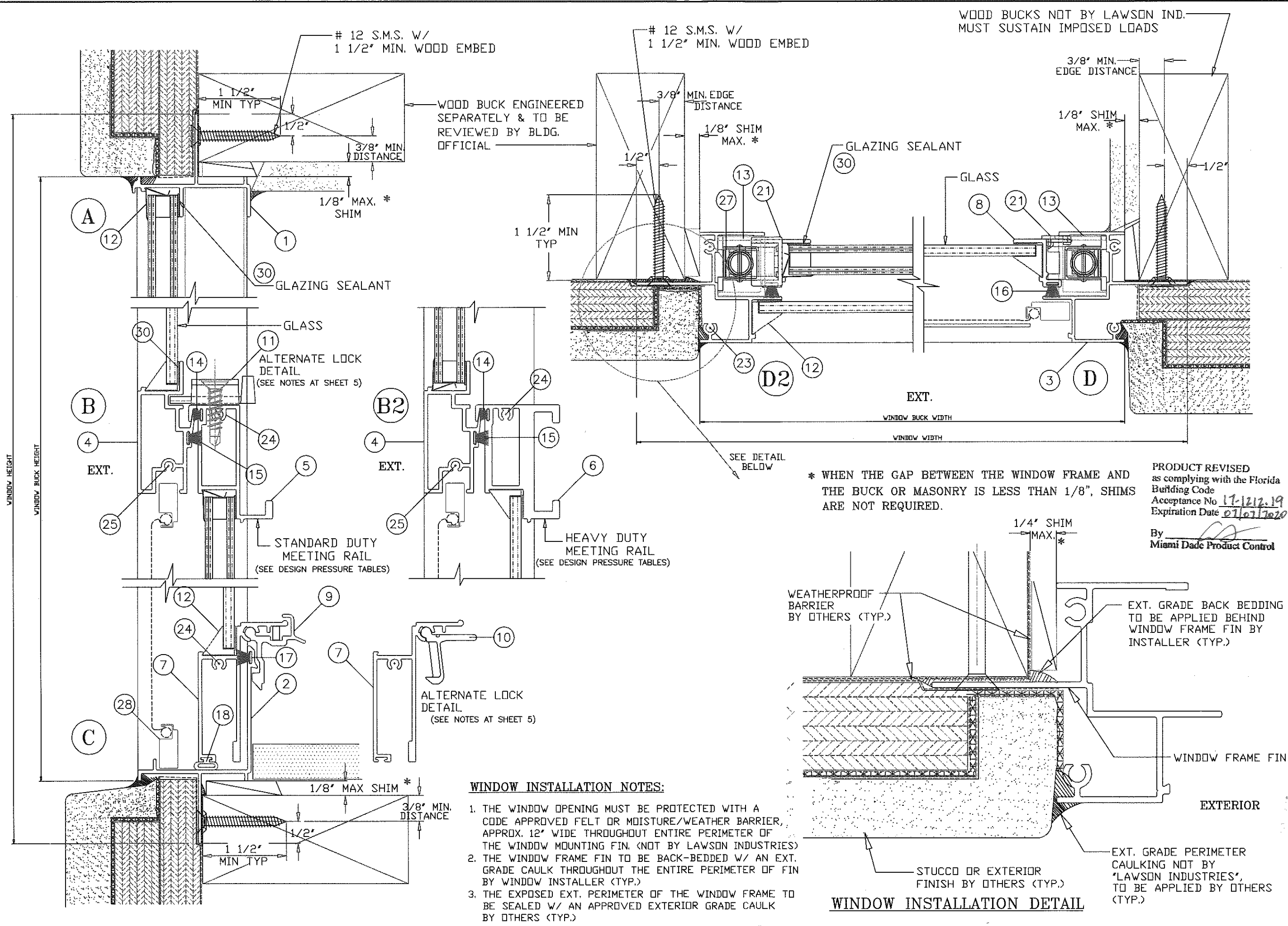

WOOD BUCKS NOT BY LAWSON IND.  
MUST SUSTAIN IMPOSED LOADS

WOOD BUCK ENGINEERED SEPARATELY & TO BE REVIEWED BY BLDG. OFFICIAL

\* WHEN THE GAP BETWEEN THE WINDOW FRAME AND THE BUCK OR MASONRY IS LESS THAN 1/8", SHIMS ARE NOT REQUIRED.

PRODUCT REVISED as complying with the Florida Building Code  
Acceptance No 17-1212-19  
Expiration Date 07/07/2020

By *[Signature]*  
Miami Dade Product Control

**WINDOW INSTALLATION NOTES:**

1. THE WINDOW OPENING MUST BE PROTECTED WITH A CODE APPROVED FELT OR MOISTURE/WEATHER BARRIER, APPROX. 12" WIDE THROUGHOUT ENTIRE PERIMETER OF THE WINDOW MOUNTING FIN. (NOT BY LAWSON INDUSTRIES)
2. THE WINDOW FRAME FIN TO BE BACK-BEDDED W/ AN EXT. GRADE CAULK THROUGHOUT THE ENTIRE PERIMETER OF FIN BY WINDOW INSTALLER (TYP.)
3. THE EXPOSED EXT. PERIMETER OF THE WINDOW FRAME TO BE SEALED W/ AN APPROVED EXTERIOR GRADE CAULK BY OTHERS (TYP.)

**WINDOW INSTALLATION DETAIL**

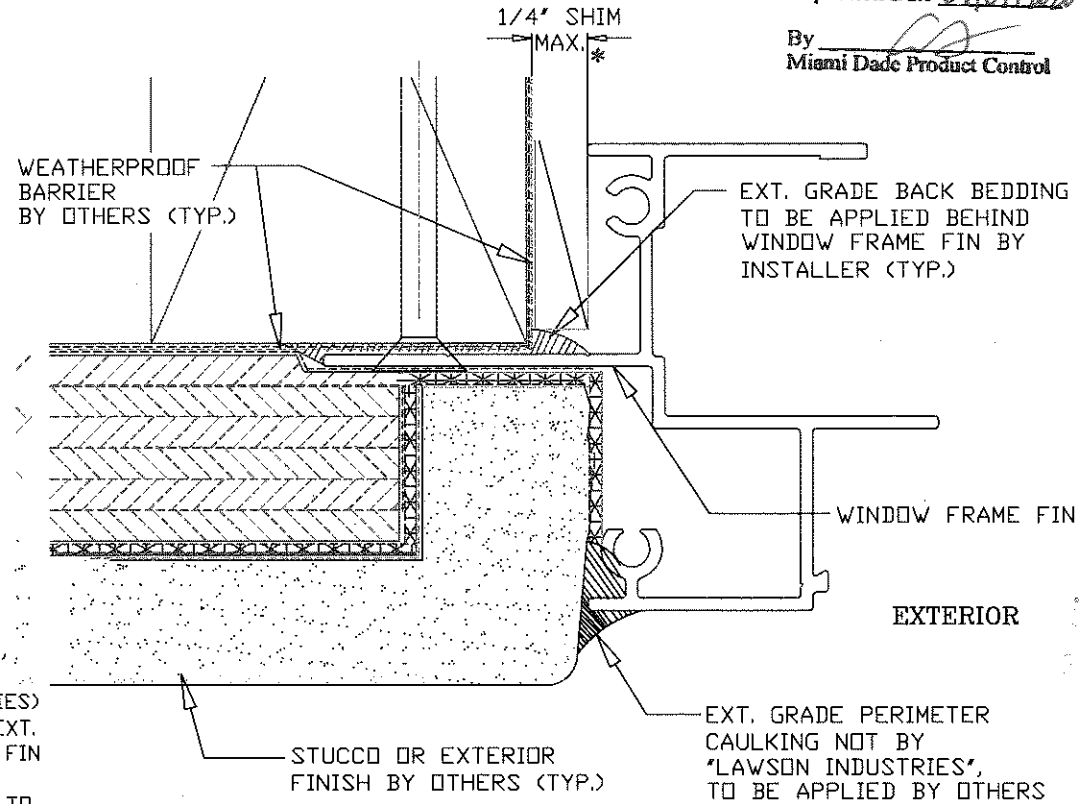

# LAWSON INDUSTRIES, INC.

MANUFACTURER OF QUALITY ALUMINUM WINDOWS AND GLASS DOORS

8501 N.W. 90 ST.  
MEDLEY, FLORIDA 33166  
PH No. (305) 696-8660

---

SH-7600 SINGLE HUNG FIN WINDOW

CROSS SECTIONAL DETAILS FOR STD/HVY DUTY MEETING RAIL

Drawing Number: L17600-0402    Sheet: 2 OF 5    Revision #: 1

---

**Revision Notes:**

B. Qualified Com Locks on all annealed windows and 1/8" temp. Changed tables to buck dims.	Date Drawn: 09/20/04
C. General notes revised to comply with the 2007 Florida Building Code.	Date Revised: 11/01/17
D. Revised to Comply w/ 2010 FBC	Scale: P
E. Revised to Comply w/ 2014 FBC	Drawn By: N. Erazo
F. Revised to Comply w/ 2017 FBC	Checked By: N. Erazo

---

THOMAS J. SOTOS  
PROFESSIONAL ENGINEER  
FL LIC. # 56225

DATE: \_\_\_\_\_

7600 Non Impact Single Hung Window Test # FTL 5284 A-1 - 1/4" Annealed Pressure Limited to Negative 100psf. Fin Frame w/ Standard Meeting Rail					
Buck Width	Buck Height	P(+) psf	P(-) psf	Each Jamb Anchors	Head & Sill Anchors
18.125	25	70.00	100.00	3	2
18.125	37.375	70.00	100.00	4	2
18.125	49.625	70.00	100.00	6	2
18.125	57	70.00	100.00	7	2
18.125	62	70.00	100.00	7	2
18.125	73.25	70.00	100.00	9	2
25.5	25	70.00	100.00	4	2
25.5	37.375	70.00	100.00	5	3
25.5	49.625	70.00	100.00	7	3
25.5	57	70.00	100.00	8	3
25.5	62	70.00	100.00	9	3
25.5	73.25	70.00	100.00	11	3
36	25	70.00	100.00	4	3
36	37.375	70.00	100.00	6	4
36	49.625	70.00	95.62	8	4
36	57	70.00	90.30	9	4
36	62	70.00	87.97	10	4
36	73.25	70.00	85.76	12	4
52.125	25	70.00	96.80	6	4
52.125	37.375	70.00	71.11	6	4
52.125	49.625	58.30	58.30	7	4
52.125	57	53.41	53.41	7	4
52.125	62	50.86	50.86	8	4
52.125	73.25	46.70	46.70	9	4

7600 Non Impact Single Hung Window Test # FTL 4344 - 1/4" Annealed Pressure Limited to Negative 100psf. Fin Frame w/ Heavy Duty Rail					
Buck Width	Buck Height	P(+) psf	P(-) psf	Each Jamb Anchors	Head & Sill Anchors
18.125	25	70.00	100.00	4	2
18.125	37.375	70.00	100.00	4	3
18.125	49.625	70.00	100.00	7	2
18.125	57	70.00	100.00	7	2
18.125	62	70.00	100.00	8	2
18.125	73.25	70.00	100.00	10	2
25.5	25	70.00	100.00	4	3
25.5	37.375	70.00	100.00	6	3
25.5	49.625	70.00	100.00	8	3
25.5	57	70.00	100.00	8	3
25.5	62	70.00	100.00	10	3
25.5	73.25	70.00	100.00	12	3
36	25	70.00	100.00	4	4
36	37.375	70.00	100.00	7	4
36	49.625	70.00	100.00	10	6
36	57	70.00	100.00	11	6
36	62	70.00	100.00	12	6
36	73.25	70.00	86.00	12	4
52.125	25	70.00	100.00	6	6
52.125	37.375	70.00	100.00	8	7
52.125	49.625	70.00	93.00	11	7
52.125	57	70.00	74.90	10	7
52.125	62	66.10	66.10	11	6
52.125	73.25	57.70	57.70	11	6

7600 Non Impact Single Hung Window Test # FTL 4406 - 3/16" Annealed Pressure Limited to Negative 100psf. Fin Frame w/ Standard Duty Rail					
Buck Width	Buck Height	P(+) psf	P(-) psf	Each Jamb Anchors	Head & Sill Anchors
18.125	25	70.00	100.00	4	2
18.125	37.375	70.00	100.00	4	3
18.125	49.625	70.00	100.00	7	2
18.125	57	70.00	100.00	7	2
18.125	62	70.00	100.00	8	2
18.125	73.25	70.00	100.00	10	2
25.5	25	70.00	100.00	4	3
25.5	37.375	70.00	100.00	6	3
25.5	49.625	70.00	100.00	8	3
25.5	57	70.00	100.00	8	3
25.5	62	70.00	100.00	10	3
25.5	73.25	70.00	89.80	11	3
36	25	70.00	100.00	4	4
36	37.375	70.00	100.00	7	4
36	49.625	70.00	93.30	8	4
36	57	70.00	82.00	8	4
36	62	70.00	77.20	10	4
36	73.25	66.80	66.80	10	4
52.125	25	70.00	100.00	6	6
52.125	37.375	70.00	76.13	7	6
52.125	49.625	62.42	62.42	8	6
52.125	57	52.70	52.70	8	4
52.125	62	49.90	49.90	8	4
52.125	73.25	45.80	45.80	10	4

7600 Non Impact Single Hung Window Test # FTL 4324 - 3/16" Tempered Pressure Limited to Negative 100psf. Fin Frame w/ Heavy Duty Rail					
Buck Width	Buck Height	P(+) psf	P(-) psf	Each Jamb Anchors	Head & Sill Anchors
18.125	25	70	100.00	4	2
18.125	37.375	70.00	100.00	4	3
18.125	49.625	70.00	100.00	7	2
18.125	57	70.00	100.00	7	2
18.125	62	70.00	100.00	8	2
18.125	73.25	70.00	100.00	10	2
25.5	25	70.00	100.00	4	3
25.5	37.375	70.00	100.00	6	3
25.5	49.625	70.00	100.00	8	3
25.5	57	70.00	100.00	8	3
25.5	62	70.00	100.00	10	3
25.5	73.25	70.00	100.00	12	3
36	25	70.00	100.00	4	4
36	37.375	70.00	100.00	7	4
36	49.625	70.00	100.00	10	6
36	57	70.00	100.00	11	6
36	62	70.00	100.00	12	6
36	73.25	70.00	100.00	15	6
52.125	25	70.00	100.00	6	6
52.125	37.375	70.00	100.00	8	7
52.125	49.625	70.00	99.87	12	7
52.125	57	70.00	91.49	12	7
52.125	62	70.00	87.12	14	7
52.125	73.25	70.00	80.00	15	7

7600 Non Impact Single Hung View Window Test # FTL 4363 - 3/16" Annealed View Fin Frame w/ Heavy Duty Rail TABLE V-1						
CODE SIZE	Buck Width	Buck Height	P(+) psf	P(-) psf	Each Jamb Anchors	Head & Sill Anchors
14 - 2	18.125	49.625	70.0	100.0	8	3
14 - 3	18.125	49.625	70.0	100.0	10	3
15 - 3	18.125	62	70.0	100.0	10	3
15 - 4	18.125	62	70.0	100.0	11	3
16 - 4	18.125	73.25	70.0	100.0	11	3
16 - 45	18.125	73.25	70.0	100.0	11	3
16 - 5	18.125	73.25	70.0	100.0	12	3
H34 - 2	25.5	49.625	70.0	84.5	7	3
H34 - 3	25.5	49.625	70.0	104.0	8	3
H35 - 3	25.5	62	70.0	72.4	7	3
H35 - 4	25.5	62	70.0	84.5	8	3
H36 - 4	25.5	73.25	64.4	64.4	8	3
H36 - 45	25.5	73.25	70.0	70.2	8	3
H36 - 5	25.5	73.25	70.0	74.2	10	3
24 - 2	36	49.625	63.8	63.8	7	3
24 - 3	36	49.625	70.0	75.2	7	3
25 - 3	36	62	55.2	55.2	7	3
25 - 4	36	62	63.8	63.8	8	3
26 - 4	36	73.25	49.1	49.1	7	3
26 - 45	36	73.25	53.3	53.3	8	3
26 - 5	36	73.25	56.6	56.6	8	3
34 - 2	52.125	49.625	44.6	44.6	6	3
34 - 3	52.125	49.625	49.0	49.0	7	3
35 - 3	52.125	62	41.5	41.5	7	3
35 - 4	52.125	62	44.6	44.6	7	4
36 - 4	52.125	73.25	39.0	39.0	8	3
36 - 45	52.125	73.25	40.8	40.8	8	3
36 - 5	52.125	73.25	42.2	42.2	8	3

7600 Non Impact Single Hung View Window Test # FTL 4345 - 3/16" Tempered View Pressure Limited to Negative 100psf. Fin Frame w/ Heavy Duty Rail - TABLE V-2						
CODE SIZE	Buck Width	Buck Height	P(+) psf	P(-) psf	Each Jamb Anchors	Head & Sill Anchors
14 - 2	18.125	49.625	70.0	100.0	7	2
14 - 3	18.125	49.625	70.0	100.0	7	2
15 - 3	18.125	62	70.0	100.0	8	2
15 - 4	18.125	62	70.0	100.0	8	2
16 - 4	18.125	73.25	70.0	100.0	10	2
16 - 45	18.125	73.25	70.0	100.0	10	2
16 - 5	18.125	73.25	70.0	100.0	10	2
H34 - 2	25.5	49.625	70.0	100.0	8	3
H34 - 3	25.5	49.625	70.0	100.0	8	3
H35 - 3	25.5	62	70.0	100.0	10	3
H35 - 4	25.5	62	70.0	100.0	10	3
H36 - 4	25.5	73.25	70.0	100.0	12	3
H36 - 45	25.5	73.25	70.0	100.0	12	3
H36 - 5	25.5	73.25	70.0	100.0	12	3
24 - 2	36	49.625	70.0	100.0	10	3
24 - 3	36	49.625	70.0	100.0	10	4
25 - 3	36	62	70.0	100.0	12	4
25 - 4	36	62	70.0	100.0	12	6
26 - 4	36	73.25	70.0	100.0	15	4
26 - 45	36	73.25	70.0	100.0	15	6
26 - 5	36	73.25	70.0	100.0	15	6
34 - 2	52.125	49.625	70.0	100.0	12	4
34 - 3	52.125	49.625	70.0	100.0	12	6
35 - 3	52.125	62	70.0	92.9	15	6
35 - 4	52.125	62	70.0	87.6	14	7
36 - 4	52.125	73.25	70.0	84.1	16	7
36 - 45	52.125	73.25	70.0	81.3	15	7
36 - 5	52.125	73.25	70.0	80.0	15	7

**WATSON INDUSTRIES, INC.**

8501 N.W. 90 ST.  
MEDLEY, FLORIDA 33166  
PH No. (305) 696-8660

**MANUFACTURER OF QUALITY ALUMINUM WINDOWS AND GLASS DOORS**

**SH-7600 SINGLE HUNG FIN WINDOW**

DESIGN LOAD CHARTS W/ MONOLITHIC GLASS

Drawing Number: L7600--0402      Sheet: 3 OF 5      Revision #: \_\_\_\_\_

Product Reference Number: \_\_\_\_\_

---

**Revision Notes:**

B. Qualified Cam Locks on all annealed windows and 1/8" temp. Changed tables to buck dims.

C. General notes revised to comply with the 2007 Florida Building Code.

D. Revised to Comply w/ 2010 FBC

E. Revised to Comply w/ 2014 FBC

F. Revised to Comply w/ 2017 FBC

---

Drawn By: N. Erazo      Date Drawn: 09/20/04

Checked By: N. Erazo      Date Checked: 11/01/17

Revision Level: F

---

**THOMAS J. SOTOS**  
PROFESSIONAL ENGINEER  
FL LIC # 56226

DATE: \_\_\_\_\_



7600 Non Impact Single Hung Window Test # FTL 5284 A-4 - 1/8" Annealed Pressure Limited to Negative 100psf. Fin Frame w/ Standard Meeting Rail					
Buck Width	Buck Height	P(+) psf	P(-) psf	Each Jamb Anchors	Head & Sill Anchors
18.125	25	70.00	100.00	3	2
18.125	37.375	70.00	100.00	4	2
18.125	49.625	70.00	100.00	6	2
18.125	57	70.00	85.30	6	2
18.125	62	70.00	78.50	6	2
18.125	73.25	66.80	66.80	6	1
25.5	25	70.00	100.00	4	2
25.5	37.375	70.00	95.00	5	3
25.5	49.625	70.00	77.90	6	2
25.5	57	67.40	67.40	6	2
25.5	62	61.40	61.40	6	2
25.5	73.25	50.40	50.40	6	2
36	25	70.00	91.03	4	3
36	37.375	62.20	62.20	4	3
36	49.625	52.50	52.50	5	3
36	57	49.90	49.90	5	3
36	62	47.40	47.40	6	3
36	73.25	41.40	41.40	6	2
52.125	25	60.11	60.11	4	3
52.125	37.375	44.16	44.16	4	3
52.125	49.625	31.40	31.40	4	3
52.125	57	31.00	31.00	5	3
52.125	62	30.80	30.80	5	3
52.125	73.25	29.00	29.00	6	3

7600 Non Impact Single Hung Window Test # FTL 5284 A-3 - 1/2" Overall Insulated w/ 1/8" Annealed Pressure Limited to Negative 100psf. Fin Frame w/ Standard Meeting Rail					
Buck Width	Buck Height	P(+) psf	P(-) psf	Each Jamb Anchors	Head & Sill Anchors
18.125	25	70.00	100.00	3	2
18.125	37.375	70.00	100.00	4	2
18.125	49.625	70.00	100.00	6	2
18.125	57	70.00	100.00	7	2
18.125	62	70.00	100.00	7	2
18.125	73.25	70.00	100.00	9	2
25.5	25	70.00	100.00	4	2
25.5	37.375	70.00	100.00	5	3
25.5	49.625	70.00	100.00	7	3
25.5	57	70.00	100.00	8	3
25.5	62	70.00	100.00	9	3
25.5	73.25	70.00	90.80	10	3
36	25	70.00	100.00	4	3
36	37.375	70.00	100.00	6	4
36	49.625	70.00	94.50	8	4
36	57	70.00	89.80	9	4
36	62	70.00	85.30	10	4
36	73.25	70.00	74.50	11	4
52.125	25	70.00	96.80	6	4
52.125	37.375	70.00	71.11	6	4
52.125	49.625	56.50	56.50	7	4
52.125	57	53.41	53.41	7	4
52.125	62	50.86	50.86	8	4
52.125	73.25	46.70	46.70	9	4

7600 Non Impact Single Hung Window Test # FTL 4350 - 1/2" Overall Insulated w/ 1/8" Annealed Pressure Limited to Negative 100psf. Fin Frame w/ Heavy Duty Rail					
Buck Width	Buck Height	P(+) psf	P(-) psf	Each Jamb Anchors	Head & Sill Anchors
18.125	25	70.00	100.00	4	2
18.125	37.375	70.00	100.00	4	3
18.125	49.625	70.00	100.00	7	2
18.125	57	70.00	100.00	7	2
18.125	62	70.00	100.00	8	2
18.125	73.25	70.00	100.00	10	2
25.5	25	70.00	100.00	4	3
25.5	37.375	70.00	100.00	6	3
25.5	49.625	70.00	100.00	8	3
25.5	57	70.00	100.00	8	3
25.5	62	70.00	100.00	10	3
25.5	73.25	70.00	90.80	11	3
36	25	70.00	100.00	4	4
36	37.375	70.00	100.00	7	4
36	49.625	70.00	94.50	10	4
36	57	70.00	89.80	10	4
36	62	70.00	85.30	11	4
36	73.25	70.00	74.50	11	4
52.125	25	70.00	100.00	6	6
52.125	37.375	70.00	84.50	8	6
52.125	49.625	56.50	56.50	7	4
52.125	57	55.90	55.90	8	6
52.125	62	55.50	55.50	8	6
52.125	73.25	52.50	52.50	10	6

7600 Non Impact Single Hung Window Test # FTL 5284 A-5 - 1/8" Tempered Pressure Limited to Negative 100psf. Fin Frame w/ Standard Meeting Rail					
Buck Width	Buck Height	P(+) psf	P(-) psf	Each Jamb Anchors	Head & Sill Anchors
18.125	25	70.00	100.00	4	2
18.125	37.375	70.00	100.00	4	3
18.125	49.625	70.00	100.00	7	2
18.125	57	70.00	100.00	7	2
18.125	62	70.00	100.00	8	2
18.125	73.25	70.00	100.00	10	2
25.5	25	70.00	100.00	4	3
25.5	37.375	70.00	100.00	6	3
25.5	49.625	70.00	100.00	8	3
25.5	57	70.00	100.00	8	3
25.5	62	70.00	100.00	10	3
25.5	73.25	70.00	100.00	12	3
36	25	70.00	100.00	4	4
36	37.375	70.00	100.00	7	4
36	49.625	70.00	100.00	10	6
36	57	70.00	100.00	11	6
36	62	70.00	100.00	12	6
36	73.25	70.00	86.00	12	4
52.125	25	70.00	100.00	6	6
52.125	37.375	70.00	100.00	8	7
52.125	49.625	70.00	93.00	11	7
52.125	57	70.00	74.90	10	7
52.125	62	66.10	66.10	11	6
52.125	73.25	57.70	57.70	11	6

7600 Non Impact Single Hung Window Test # FTL 4351 - 1/2" Overall Insulated w/ 1/8" Tempered Pressure Limited to Negative 100psf. Fin Frame w/ Heavy Duty Rail					
Buck Width	Buck Height	P(+) psf	P(-) psf	Each Jamb Anchors	Head & Sill Anchors
18.125	25	70.00	100.00	4	2
18.125	37.375	70.00	100.00	4	3
18.125	49.625	70.00	100.00	7	2
18.125	57	70.00	100.00	7	2
18.125	62	70.00	100.00	8	2
18.125	73.25	70.00	100.00	10	2
25.5	25	70.00	100.00	4	3
25.5	37.375	70.00	100.00	6	3
25.5	49.625	70.00	100.00	8	3
25.5	57	70.00	100.00	8	3
25.5	62	70.00	100.00	10	3
25.5	73.25	70.00	100.00	12	3
36	25	70.00	100.00	4	4
36	37.375	70.00	100.00	7	4
36	49.625	70.00	100.00	10	6
36	57	70.00	100.00	11	6
36	62	70.00	100.00	12	6
36	73.25	70.00	100.00	15	6
52.125	25	70.00	100.00	6	6
52.125	37.375	70.00	100.00	8	7
52.125	49.625	70.00	99.87	12	7
52.125	57	70.00	91.49	12	7
52.125	62	70.00	87.12	14	7
52.125	73.25	70.00	80.00	15	7

**Glazing Description, Details & Options**

EXT. (12) (29) (30) (31)  
3/8" GLAZING BITE

**MONOLITHIC GLASS**  
ANNEALED OR TEMPERED  
1/8", 3/16" OR 1/4" THICK  
(SEE DESIGN PRESSURE TABLES)

EXT. (12) (29) (30) (31)  
3/8" GLAZING BITE

**1/2" OVERALL INSULATED GLASS**  
CONSIST OF:  
1/8" ANNEALED OR TEMPERED LITE  
+ 1/4" AIR SPACE  
+ 1/8" ANNEALED OR TEMPERED LITE  
(SEE DESIGN PRESSURE TABLES)

**Glazing Sealant Types & Options**

- 1) Schnee-Morehead 5731
- 2) Schnee-Morehead 5732
- 3) GE SCS 1000 Clear Silicone
- 4) Dow Corning Clear Silicone

PRODUCT REVISED  
as complying with the Florida  
Building Code  
Acceptance No 17-1212-19  
Expiration Date 07/01/2020

By CA  
Miami Dade Product Control

**LAWSON INDUSTRIES, INC.**

8501 N.W. 90 ST.  
MEDLEY, FLORIDA 33166  
PH No. (305) 696-8860

**MANUFACTURER OF QUALITY ALUMINUM WINDOWS AND GLASS DOORS**

**SH-7600 SINGLE HUNG FIN WINDOW**

DESIGN LOAD CHARTS W/ MONOLITHIC & INSULATED GLASS, GLAZING DETAILS

<p>Revision Notes:</p> <p>B. Qualified Cam Locks on all annealed windows and 1/8" temp. Changed tables to buck dims.</p> <p>C. General notes revised to comply with the 2007 Florida Building Code.</p> <p>D. Revised to Comply w/ 2010 FBC</p> <p>E. Revised to Comply w/ 2014 FBC</p> <p>F. Revised to Comply w/ 2017 FBC</p>	<p>Product Reference Number: 17600-0402</p> <p>Sheet: 4 OF 5</p> <p>Revision #: 4 OF 5</p>	<p>Drawn By: N. Errazo</p> <p>Checked By: N. Errazo</p> <p>Revision Level: P</p> <p>Date Drawn: 09/20/04</p> <p>Date Revised: 11/01/17</p>
---	--	--

THOMAS J. SOTOS  
PROFESSIONAL ENGINEER  
FL No. 55225

DATE

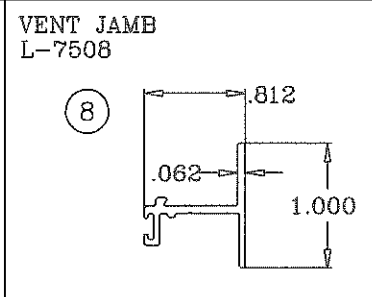
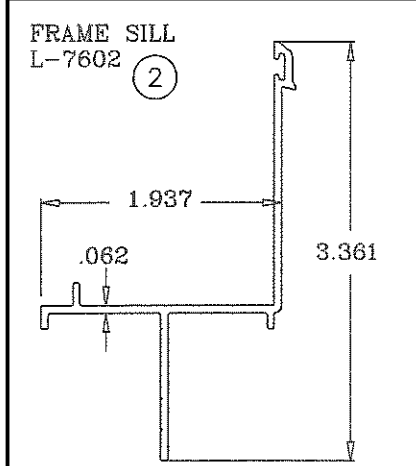
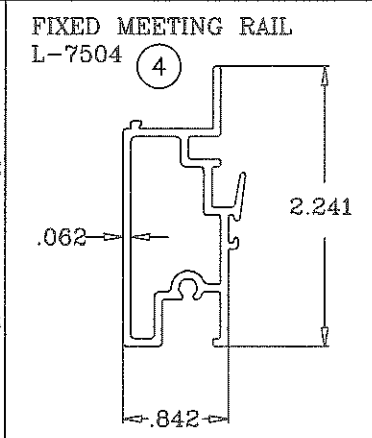
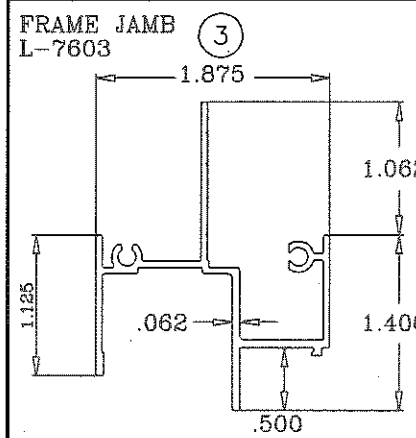
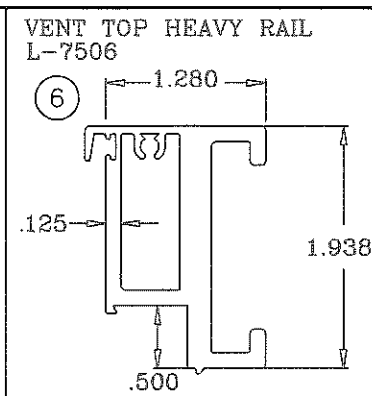
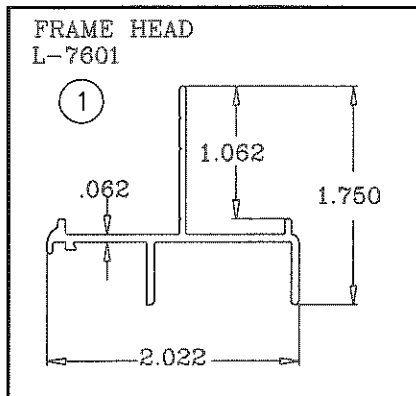

\* NOTE:  
ALL DIMENSIONS ARE  
INCHES UNITS

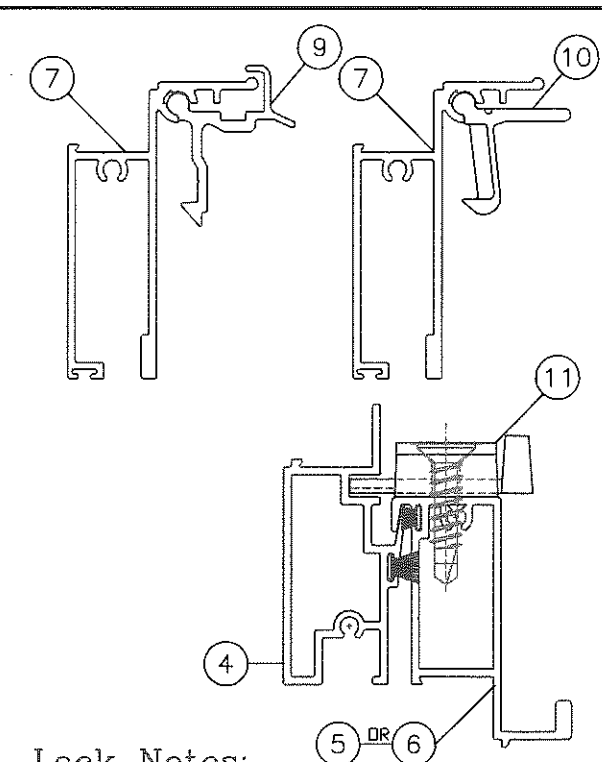
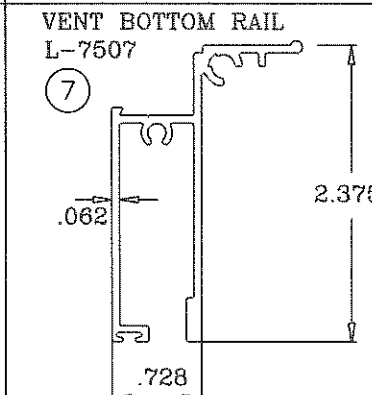
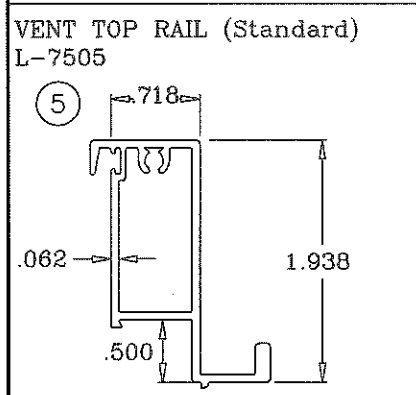
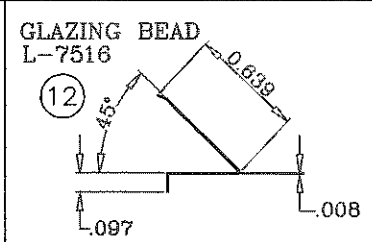
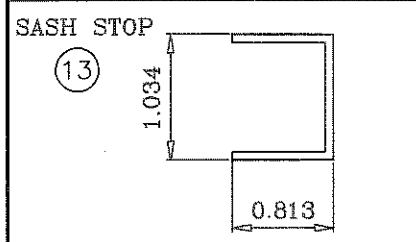

**Lock Notes:**  
 1. BOTH EXTRUDED ALUMINUM AND PLASTIC LIFT HANDLE LOCKS ARE QUALIFIED FOR USE ON ALL WINDOWS.  
 2. THE CAM LOCK IS QUALIFIED FOR USE ON ALL ANNEALED WINDOWS AND 1/8" TEMPERED WINDOWS ONLY.  
 3. TWO (2) LOCKS ARE REQUIRED PER EACH SASH.  
**LOCK (LATCH AND SWEEP) OPTIONS**

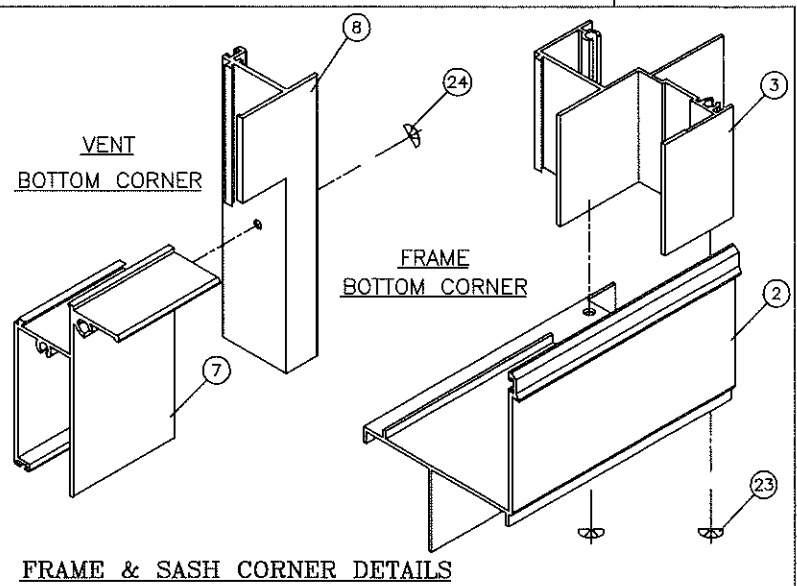
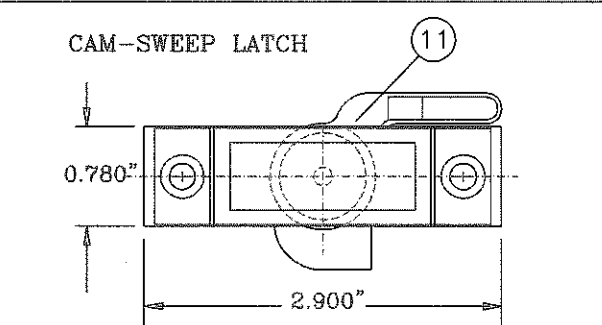

**SH7600 FIN WINDOW BILL OF MATERIALS**

ITEM #	PART #	DRWG. #	REQD.	DESCRIPTION	REMARKS
1	L-7601	LII-123	1	FRAME HEAD	6063-T6 ALUMINUM
2	L-7602	LII-122	1	FRAME SILL	6063-T6 ALUMINUM
3	L-7603	LII-128	2	FRAME JAMB	6063-T6 ALUMINUM
4	L-7504	LII-129	1	FIXED MEETING RAIL	6005-T5 ALUMINUM
5	L-7505	LII-125	1	VENT TOP RAIL STD. DUTY	6005-T5 ALUMINUM
6	L-7506	LII-126	1	VENT TOP RAIL HVY DUTY	6005-T5 ALUMINUM
7	L-7507	LII-136	1	VENT BOTTOM RAIL	6005-T5 ALUMINUM
8	L-7508	LII-124	1	VENT JAMB	6063-T5 ALUMINUM
9	*	*	2	VENT LATCH / LIFT LOCK	6063-T6 ALUMINUM
10	*	*	2	VENT LATCH / LIFT LOCK	INJECTED MOLDED
11	*	*	2	VENT LATCH / SWEEP	DIE CAST
12	L-7516	*	AS REQD.	GLAZING BEAD	ROLL FORMED ALUMINUM
13	*	*	2	VENT/SASH STOP	1 PER JAMB
14	*	SCHLEGEL	AS REQD.	TOP RAIL WEATHERSTRIP	.187' X 150' PILE
15	*	ULTRAFAB	AS REQD.	FXD. RAIL WEATHERSTRIP	.187' X 250' FIN SEAL
16	*	ULTRAFAB	AS REQD.	VENT JAMB WEATHERSTRIP	.187' X .280' FIN SEAL
17	*	ULTRAFAB	AS REQD.	FRAME SILL WEATHERSTRIP	.187' X .250' FIN SEAL
18	*	*	AS REQ'D.	BOTT. RAIL WEATHERSTRIP	3/8' DIA. BULB
19	*	*	2	VENT/SILL OPEN CELL PAD	1'x1'x1/2' FOAM PAD
20	*	*	2	SILL/JAMB JOINT GASKET	1/16' CLOSED CELL FOAM
21	L-7523	*	2	VENT TOP GUIDE / CAM	1 AT EACH END OF RAIL
22	L-7524	*	4	VENT JAMB FACE GUIDE	2 PER VENT JAMB
23	*	*	8	FRAME ASSEMBLY SCREWS	# 8 X 3/4' P.H. PHIL.
24	*	*	4	VENT ASSEMBLY SCREWS	# 8 X 1' P.H. PHILLIPS
25	*	*	2	FXD. MTG. RAIL SCREW	# 8 X 1' P.H. PHILLIPS
26	*	*	14	FRAME INSTALL'N SCREW	#10 X 1 1/4' F.H. / PHI.
27	L-7527	*	2	BLOCK & TACKLE BALANCE	1 PER JAMB
28	*	*	1	INSECT SCREEN	OPTIONAL
29	*	*	2	GLASS @ TOP & BOTTOM	See Detail @ Sheet 2 of 5
30	*	*	AS REQ'D	GLAZING SILICONE	See Detail @ Sheet 2 of 5
31	*	774-25B-767	AS REQ'D	'TruSeal' Swiggle Seal	Black -1/4' air space

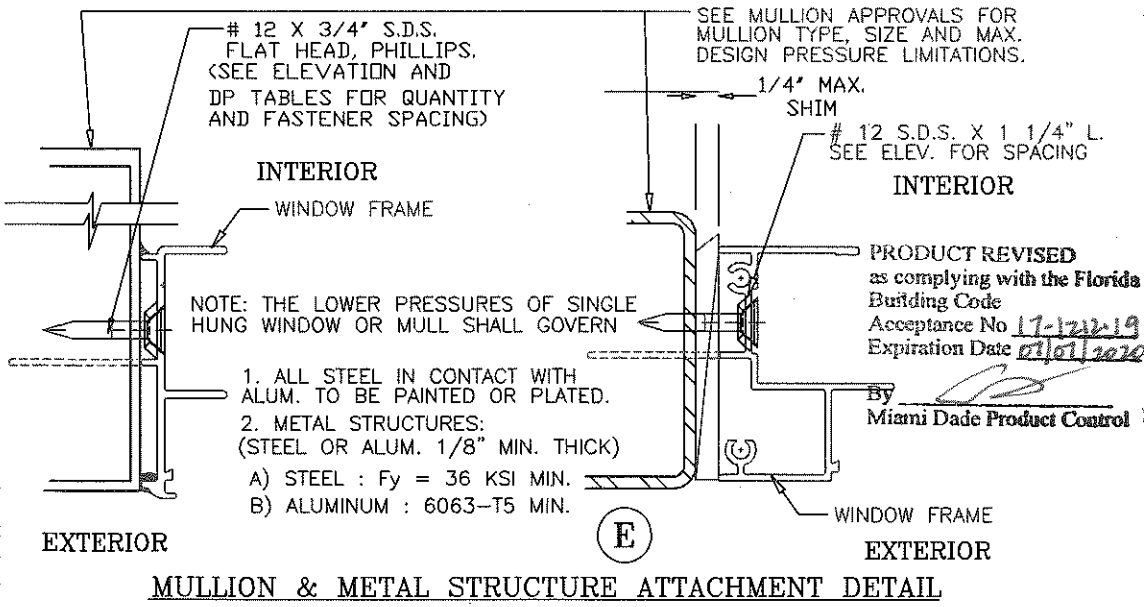

**LAWSON INDUSTRIES, INC.**

8501 N.W. 90 ST.  
MEDLEY, FLORIDA 33166  
PH No. (305) 696-8660

MANUFACTURER OF QUALITY ALUMINUM WINDOWS AND GLASS DOORS

SH-7600 SINGLE HUNG FIN WINDOW

BILL OF MATERIALS, EXTRUSION DETAILS, ASSEMBLY DETAILS, AND GLAZING DETAILS

Product Reference Number: L7600-0402

Drawing Number: L7600-0402

Sheet: 5 OF 6

Revision #:

Revisions:  
 A. Qualified Com Locks on all annealed windows and 1/8" temp. Changed tables to buck dims.  
 B. General notes revised to comply with the 2007 Florida Building Code.  
 C. Revised to Comply w/ 2010 FBC  
 D. Revised to Comply w/ 2014 FBC  
 E. Revised to Comply w/ 2017 FBC

Drawn By: N. Erazo  
 Checked By: N. Erazo  
 Date Drawn: 09/20/04  
 Date Revised: 11/01/17  
 Scale: F

THOMAS J. SOTOS  
 PROFESSIONAL ENGINEER  
 No. 55225  
 STATE OF FLORIDA  
 PROFESSIONAL ENGINEER

DATE